

COMFORT MINI CRYSTAL

codice stufa - stove code - code poele - code ofen - codico estufas

001273401 - 001273402

A	CONDOTTO ASPIRAZIONE ARIA	Ø 50 mm
	AIR INTAKE PIPE	
	CONDUIT ASPIRATION AIR	
	ZULUFTANSAUGLEITUNG	
B	CONDOTTO ESPULSIONE FUMI	Ø 80 mm
	FLUE GAS EXHAUST PIPE	
	CONDUIT EXPULSION FUMÉES	
	RAUCHABZUGSLEITUNG	
	CONDUCTO DE ASPIRACIÓN DE AIRE	
	CONDUCTO DE EXPULSIÓN DE HUMOS	

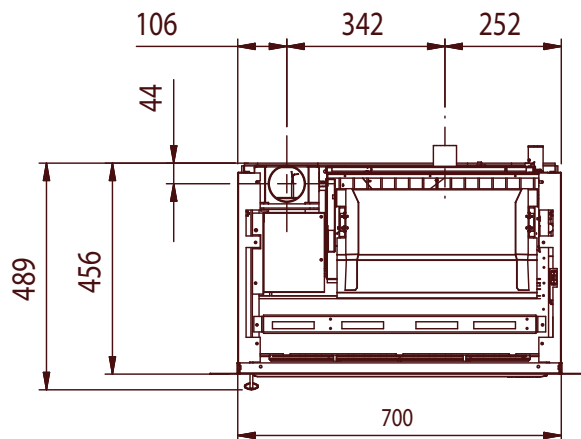
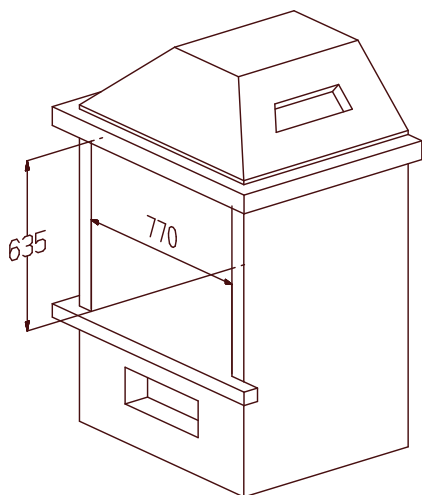
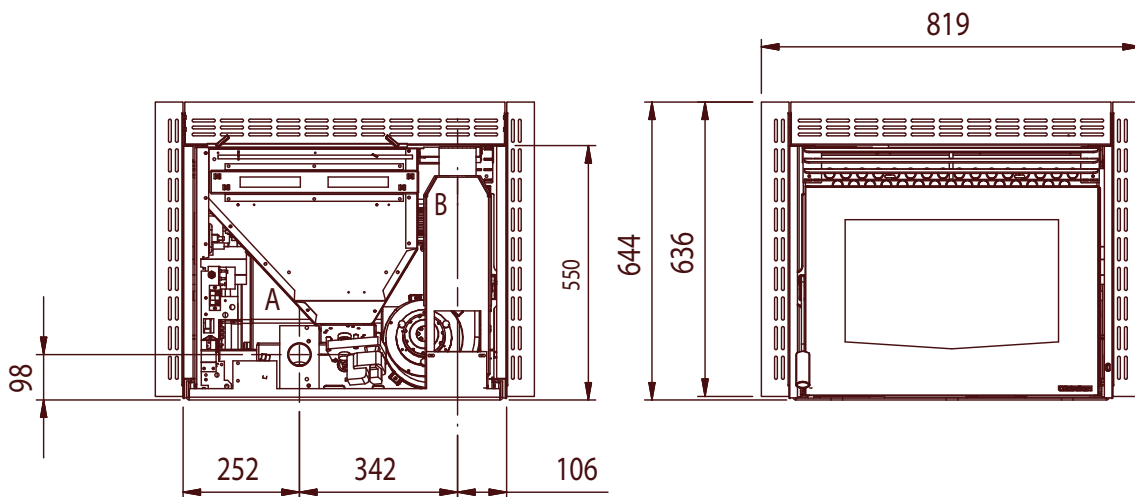

COMFORT MINI CRYSTAL

codice stufa - stove code - code poele - code ofen - codico estufas

001273401 - 001273402

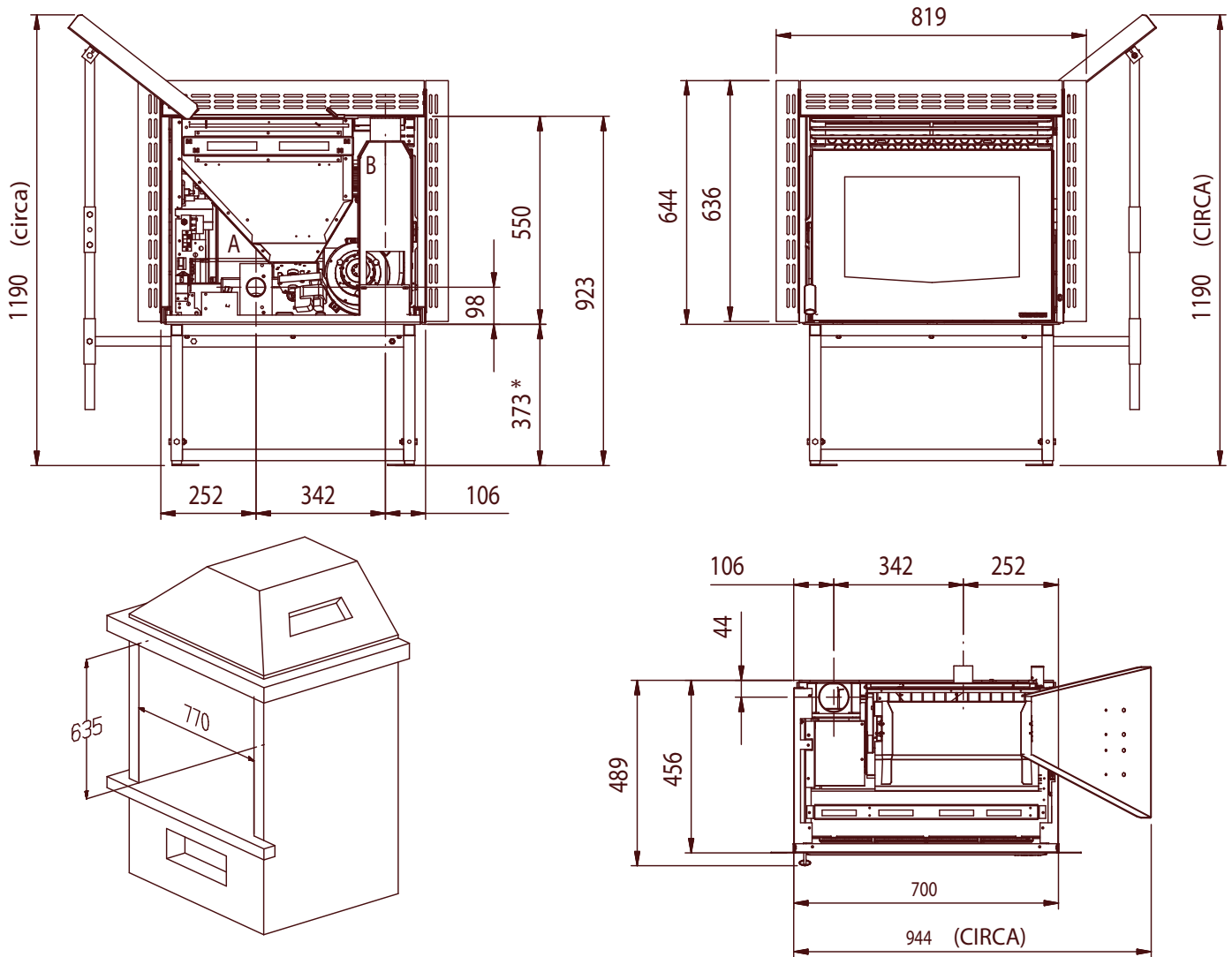

A = CONDOTTO ASPIRAZIONE ARIA Ø 50 mm

B = CONDOTTO ESPULSIONE FUMI Ø 80 mm

* = IL PARTICOLARE "TUBO REGOLAZIONE" E' PREFORATO CON 3 FORI Ø 8.5 MM A PASSO: 90 - 100: PER DIVERSE REGOLAZIONI FORARE SECONDO LE NECESSITA'

F = CANALIZZAZIONE ARIA CALDA Ø 80 mm

A = AIR INTAKE PIPE Ø 50 mm

B = FLUE GAS EXHAUST PIPE Ø 80 mm

* = THE "ADJUSTMENT PIPE" DETAIL IS PERFORATED WITH 3 HOLES Ø 8.5 MM WITH PITCH OF: 90 - 100: FOR DIFFERENT ADJUSTMENTS DRILL ACCORDING TO NECESSITY

F = DISTRIBUTED HEATING Ø 80 mm

A = CONDUIT ASPIRATION AIR Ø 50 mm

B = CONDUIT EXPULSION FUMÉES Ø 80 mm

* = L'ÉLÉMENT "TUYAU RÉGULATION" EST PERFORÉ DE 3 ORIFICES Ø 8.5 MM À PAS: 90 - 100: POUR DIFFÉRENTS RÉGLAGES, PERCER SELON LES BESOINS

F = CANALISATION Ø 80 mm

A = ZULUFTANSAUGLEITUNG Ø 50 mm

B = RAUCHABZUGSLEITUNG Ø 80 mm

* = DAS BAUTEIL "EINSTELLUNGSROHR" IST VORGEBOHRT MIT 3 BOHRUNGEN Ø 8.5 MM IM ABSTAND: 90 - 100: FÜR ANDERE EINSTELLUNGEN BOHRUNGEN NACH BEDARF HERSTELLEN

F = KANALISIERUNG Ø 80 mm

A = CONDUCTO DE ASPIRACIÓN DE AIRE Ø 50 mm

B = CONDUCTO DE EXPULSIÓN DE HUMOS Ø 80 mm

* = LA PIEZA "TUBO DE REGULACIÓN" ESTÁ PREPERFORADA CON 3 TUBOS DE Ø 8.5 MM CON PASO: 90 - 100: PARA REGULACIONES DIFERENTES, PERFORE SEGÚN SEA NECESARIO

F = CANALIZACION DE AIRE Ø 80 mm